

PAINTED MEDIAN/TRAFFIC ISLAND KERB
(PAINT TOP AND FACE OF KERB)

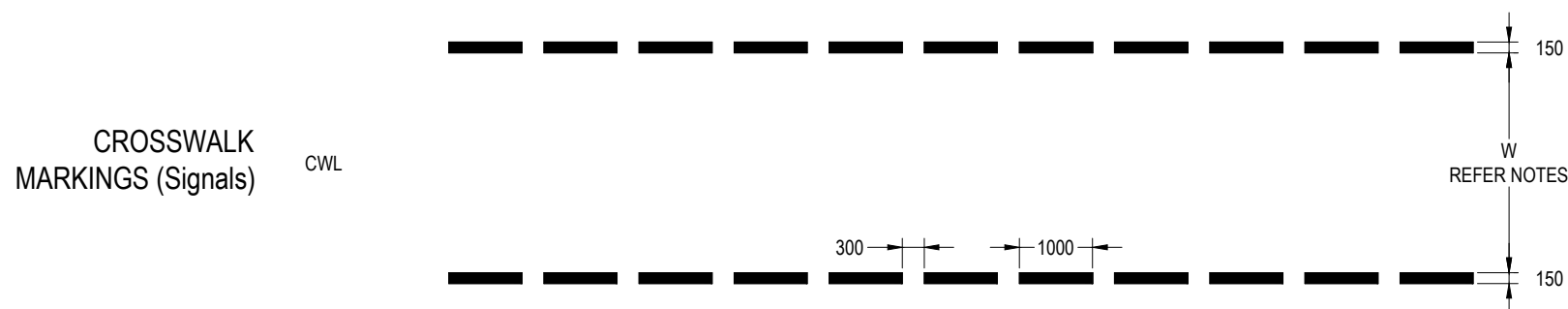
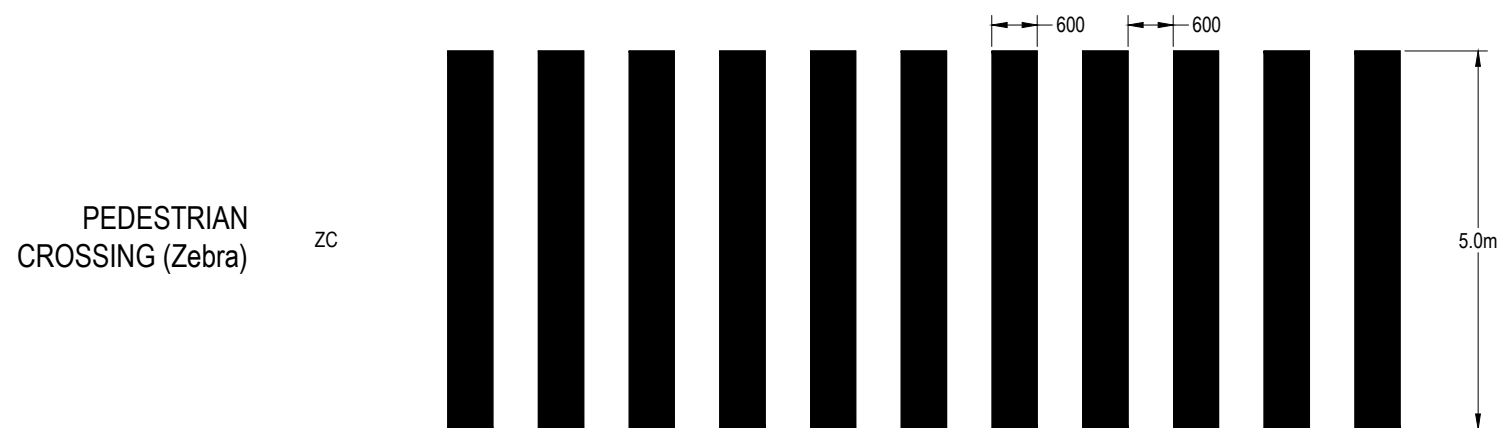

NOTES:

- FOR PARKING BAYS REFER BSD-3161.
- STOP LINES FOR BICYCLE FACILITIES AT SIGNALS TO BE 300mm (SLG).
- FOR TRAFFIC SIGNALS ON ROADS WITH A POSTED SPEED LIMIT OF 80km/h OR HIGHER, THE WIDTH OF THE STOP LINES IS TO BE INCREASED TO 600mm.
- KERB FACES ON ALL LARGE MEDIAN OR TRAFFIC ISLANDS OVER 30m ARE TO BE PAINTED WHITE 10.0m BACK FROM THE NOSE. ON SMALL ISLANDS LESS THAN 30m LONG THE FULL KERB PERIMETER OF THE MEDIAN OR TRAFFIC ISLAND IS TO BE PAINTED WHITE.
- FOR MEDIANS OR TRAFFIC ISLANDS WITH A SOLID CONCRETE NOSE, PAINT ENTIRE NOSE WHITE (TYPICALLY LANDSCAPE INFILL).
- FOR OTHER MARKINGS, REFER TO THE MUTCD.
- FOR PAVEMENT MARKING MATERIAL DETAILS, REFER REFERENCE SPECIFICATION FOR ENGINEERING WORKS S155 ROAD PAVEMENT MARKING.
- ALL DIMENSIONS IN MILLIMETRES (U.N.O.).

CROSSWALK MARKINGS - WIDTHS

APPLICATION	W
MINIMUM	3m
SUBURBAN & CITY	3m
CITY CROSSING	4m
ALL SCHOOL CROSSINGS	4m

PAINTED MEDIAN - SPACING OF BARS

- PM1. FIRST 5 BARS USE 1200mm SPACING.
PM2. INTERMEDIATE BARS USE 6000mm SPACING

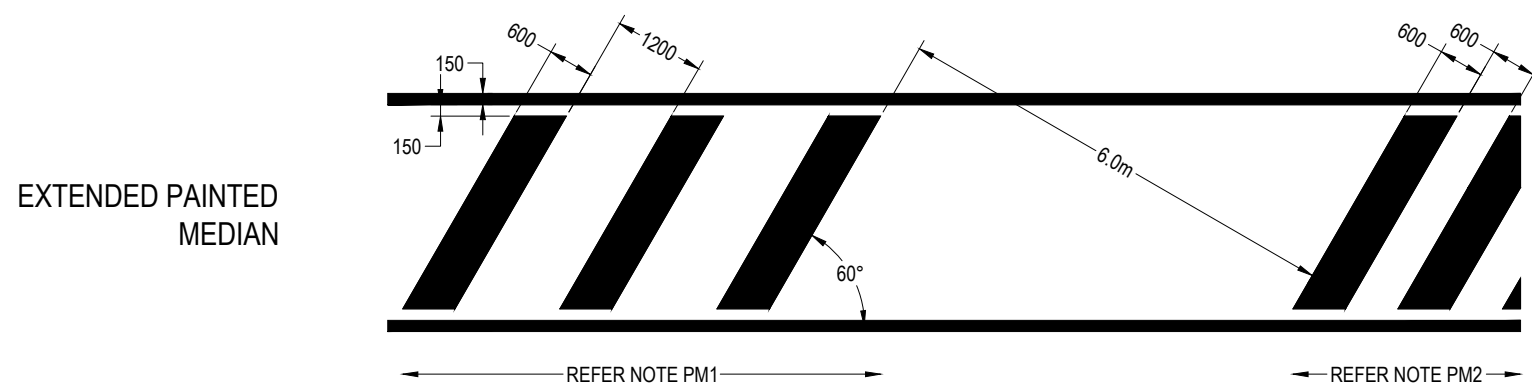

THE PURPOSE OF THIS STANDARD DRAWING IS TO PROVIDE TYPICAL DETAILS THAT SUPPORT THE DESIRED OUTCOMES OF THE BRISBANE CITY PLAN 2014 AND ASSOCIATED PLANNING SCHEME POLICIES. THE FITNESS FOR PURPOSE OF THIS STANDARD DRAWING FOR A SPECIFIC PROJECT SHOULD BE ASSESSED AND ACCEPTED BY AN APPROPRIATELY QUALIFIED DESIGNER AND/OR REGISTERED PROFESSIONAL ENGINEER OF QUEENSLAND (RPEQ).



BRISBANE CITY COUNCIL STANDARD DRAWING

**PAVEMENT MARKING
TRANSVERSE LINES
AND MARKINGS**

PUBLISH DATE	SEP 2024
SCALE	NOT TO SCALE
DRAWING NUMBER	BSD-3152
ORIGINAL SIZE	A3
REVISION	D